

Pro/ENGINEER – CAD/CAM Software Tool

Introduction Manual (Re-written for Wildfire 2)

This manual is designed to give the user a very basic understanding of the philosophy of the Pro-Engineer Wildfire (ver. 2.0) package and its user interface. The user is taken through the construction of a simple part, which illustrates a number of the basic commands of Pro-Engineer, following which the user should be in a position to explore the many other features within the ProE suite of programs. Additional support is available in the form of web based manuals and tutorials and if required more detailed training manuals, contact the Design Office for further information.

Contents

1	Key	3
2	Overview	3
2.1	Features	4
2.1.1	Construction Features	4
2.1.2	Sketched Features	4
2.1.3	Pick & Place Features	5
2.2	Modification of Features	5
3	Getting Started	5
4	User Interface	7
4.1	Start-up Display	7
4.2	Part(/Assembly) menus and Model Tree	8
4.3	Sketcher	9
4.4	Mapkeys - Hotkeys/Keyboard Shorts	10
5	Worked Example: Clamp	11
5.1	Start ProEngineer	11
5.2	Creating a part	11
5.3	Initial Material Feature / Protrusion	12
5.4	Review/Display	16

5.5	Edit Profile Dimensions	16
5.6	Save Part	17
5.7	Extruded 'Cut' using a surface reference	18
5.8	'Both' sided cut feature	19
5.9	Pick & Placed Hole	20
5.10	Sketched Hole	21
5.11	Protrusion - adding material	22
5.12	Ribs	23
5.13	Patterned Feature	23
5.14	Rounds	24
6	2-D Drawing	25
6.1	Laying out a Drawing	25
6.2	Start a Drawing	25
6.3	First View	26
6.4	Additional Views	26
6.5	Display Centerlines	27
6.6	Drawing Dimensions	28
6.7	Tidy Drawing	28
6.8	Isometric View	29
6.9	Printing a Drawing	29
7	appendix	30
7.1	Part (Assembly) Colour	30
7.2	Relations	30
7.3	Default Csys & Datum Planes	31

1 Key

To aid in the use of this handout a number of conventions/fonts/abbreviations have been used to indicate the difference between keyboard entry, menu titles, menu items etc. These are listed below:

<u>Font Used</u>	<u>Item</u>	<u>Abbreviation</u>	<u>Action</u>
Bold/Times:	menu item	LMB	Left Mouse Button
CAPITALS:	WINDOW/MENU TITLE	MMB	Middle Mouse Button
<i>Italic:</i>	<u>Keyboard inputs</u>	RMB	Right Mouse Button
Bold/Helvetica:	Hint		

Menu items followed by a → indicate that the user should follow the input to a cascaded or flyout menu. N.B. In many cases the choices required are the default and therefore do not need to be individually selected.

2 Overview

Pro/ENGINEER (Pro/E for short) is a commercial CAD/CAM package that is widely used in industry for CAD/CAM applications. It is one of the new generation of systems that not only offer a full 3-D solid modeller, in contrast to purely 2-D and surface modellers, but also parametric functionality and full associativity. This means that explicit relationships can be established between design variables and changes can be made at any point in the modelling process and the whole model is updated.

The method of constructing a model of an object is very similar to that followed in the production of a physical component. For example the manufacture of the shaped block in Figure 2 would start with the choice of construction environment, the selection of a piece of stock material followed by a series of manufacturing processes, e.g. milling, drilling, welding/sticking. Pro/E has direct analogues for most of these operations as various types of FEATURES which can be combined to generate a complete representation of a PART, Pro/E's terminology for a single component. Features fall into three main categories, Construction, Sketched and Pick/Placed.

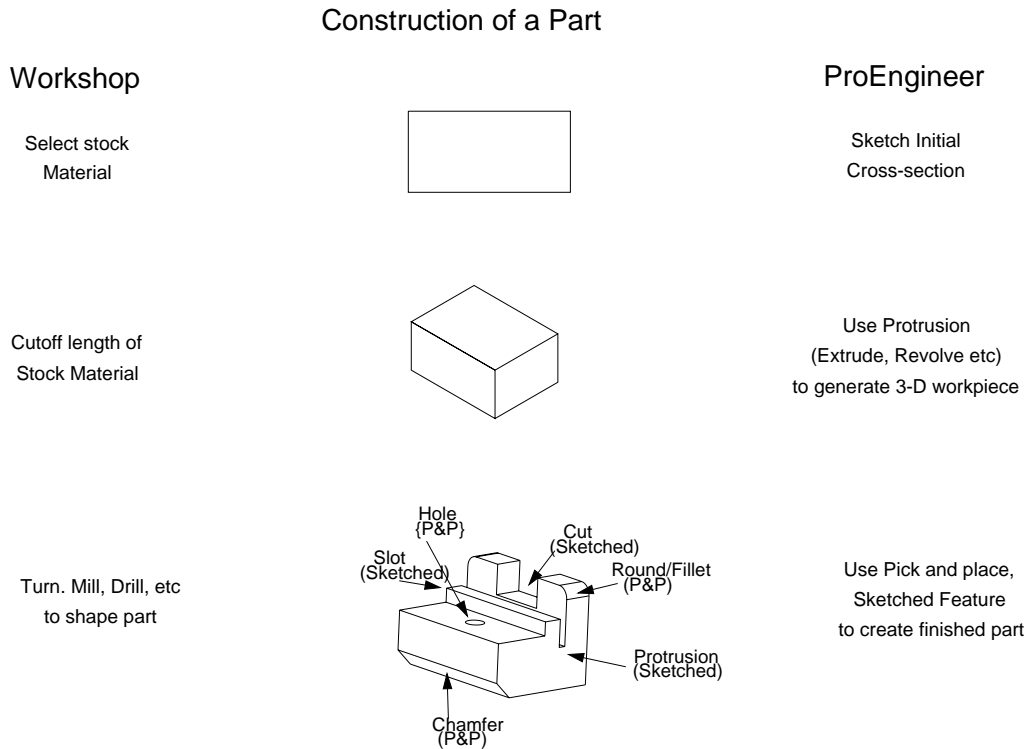

Figure 1: Comparison of physical and ProE methods of part construction

2.1 Features

2.1.1 Construction Features

These features are purely used as an aid to the construction of the part, a number of various forms are available the most commonly used are the:

Csys Coordinate systems which aid in the orientation of additional features and the assembly of the part in to subsequent assemblies. CSYS feature is normally the first feature in a part definition and is used as the basis for the placement of all subsequent features.

Datums These are an extension of the idea of construction lines as used on a traditional drawing. The most used type is a DATUM PLANE which allows a 2-D reference plane to be defined in space. Additional forms include DATUM AXES, DATUM POINTS and DATUM CURVES. It is normal to add three DEFAULT datum planes, immediately after the initial coordinate system, to effectively generate default x-y, x-z and y-z planes.

2.1.2 Sketched Features

These features are so named because they all involve the use of the SKETCHER mode within ProE, (see below for more details on its use). The main features that use this functionality are:

Protrusion Using this feature material can be added to/removed from a part by sketching

a cross-section and then extruding/revolving/sweeping the section to produce a 3-D solid/cut. A solid protrusion is normally the first non-constructional feature in a part, and is used to produce the base solid entity of the part. In the material removal mode the action is similar to a turning, saw or milling cut.

Rib This allows the user to produce a thin rib or web. This is a limited version of the protrusion function.

2.1.3 Pick & Place Features

Pick and place features tend to refer to simple or standard operations, e.g. the production of HOLES, ROUNDS and CHAMFERS. The action to produce the required effect has been preprogrammed into ProE, thus requiring the user to indicate the position of the operation on the existing model.

2.2 Modification of Features

The parametric nature of ProE means that the modification of features is relatively easy, individual features can be selected and the associated parameters/dimensions changed. However, it should be noted that ProE produces a HISTORY based model in which features can be dependant on one or more previous features for their definition, e.g. a chamfer on an edge generated by a cut or protrusion. These PARENT-CHILD dependencies mean that when a parent feature is modified its children are automatically revised to reflect the changes. N.B. Care should be taken not to remove references used by child features.

3 Getting Started

The commands given below initiate ProEngineer Wildfire on the UNIX/HP based teaching system, Linux workstations and windows NT/96/98 systems. If you wish to run ProE on another system please contact your system manager.

UNIX based Teaching Systems

- Start a suitable window manager by typing **mwm &** or **fvwm2 &** at the prompt in the initial window.
- Start ProE by typing **proewildfire2 &** at the prompt

Linux Workstations, e.g. DPO Terminals

- Start a suitable window manager by typing **mwm &** or **fvwm2 &** at the prompt in the initial window.
- Start ProE by typing **run-on-terminal proewildfire2 &** at the prompt

Windows NT/95/98 based Systems

- Close down unused programs, ProE imposes a large load on the system
- Select **Start** from the main icon bar and then select Proengineer Wildfire from the **Program** submenu. (Alternatively if click on the Wildfire icon on the desktop if a shortcut exists)

N.B. Some systems default to starting the PTC Application Manager in response to the **wildfire &** command. This is indicated by a small window in the top left hand window, to start ProE select **wildfire2** from the **Start menu**.

After a few seconds, depending on the load on the system, windows will begin to appear on the screen when the start up procedure is complete the user will be faced with a screen display similar to that shown in figure 3.

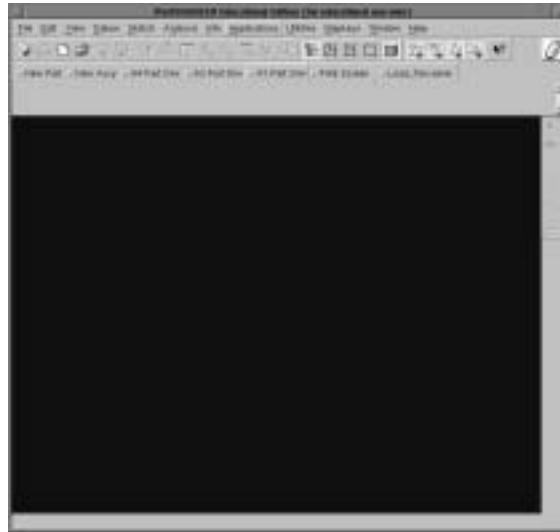

Figure 2: Basic/Start up Screen Layout

4 User Interface

4.1 Start-up Display

At startup a single model window is displayed which contains 5 main areas, each model which is loaded into the system will generate another dedicated window with the same five functional areas.

1. **Menu Bar** Ranged along the top of the screen are a number of pull down menus that access all the functions, many of which are duplicated in secondary context sensitive menus that appear during normal operation. The general operation is similar to that found in any windows compliant software. N.B. When selected the action of the menu item is displayed in the note line at the base of the main display area.

File File management sub menus - Including the ability to import and export foreign file formats.

Edit Allows modification/redefinition etc of items and also a restricted 'undo' function.

View Access to functions to change the display parameters, including orientation, colour, transparency and resolution. (A number of these functions are also available on the icon bar, see below)

Insert Gives direct access to the constructional tools, e.g. create holes, protrusions.

(Sketch) (N.B. Only visible in Sketch mode) Access to functions used while in sketcher mode, e.g. draw line, align, modify.

analysis Functions to investigate dimension and mass properties of a part. (In multi-body assemblies, interference information is available here)

Info Information about the construction, parent-child relationships etc of the current model.

Applications Access to additional PTC applications, see other manuals/help files for further information.

Tools Access to functions to change the user interface, not normally required for general use.

Window Allows user to switch input between windows etc. N.B. To change focus to a particular part window press CTRL-A while the mouse pointer is over that window.

CUED Menu access to a limited number of CUED/user defined Mapkeys

Help Access to ProEngineer manuals. Select **Pro/help** followed by **Products**, in the web browser to gain access to the online ProE manuals.

2. **Icon Bars** Icons that mimic the functions found in the pull down menus can be arranged in three positions below the pull down menus, and to the left and right of the main window. These can be simply adjusted by selecting the RHB or via the Utilities pulldown menu.

Top Menu Bar By default the main file, view/display configuration function icons are arranged here. Information about a icon's action can be obtained by placing the mouse pointer over an icon. 'Greyed' icons indicate actions that are currently unavailable. N.B. During certain operations additional icons may appear.

Right Side Icon Bar By default this icon bar displays access to the datum generation icons (identical function to the datum pull down menu see above) together with a number of sets of context sensitive icons.

3. **Message Window** This is a scroll-able window in which information on the system status and prompts for inputs are displayed. If the system is not responding look at this window as it normally indicates what is wrong. Typically it is waiting for an user input and the window has been over written.
4. **Display/Drawing Window** The large blue window is the main window in which the model or drawing is displayed. When a model is active the display can be manipulated using mouse/key combinations (see below) and commonly used commands can be accessed via floating menus (Press the RMB over the area). N.B. immediately below this window is a line which continuously displays simple help information, in particular button/menu item actions. General keyboard input is also shown here, notably mapkey shortcuts.
5. **Navigator** Area to the left of the main drawing screen that allows information about the model, directory structure etc to be displayed.
6. **Browser** Embedded web browser, accessible by clicking on the small arrows ('sash controls') at the righthand edge of the Navigator area.

4.2 Part(/Assembly) menus and Model Tree

As soon as a part (or assembly) is loaded, or a new entity started additional information will appear on the screen, notably

1. Additional icons in the top and right hand icon areas associated with image control and feature construction.

In main cases clicking on a top level icon will initiate a series of sub menus/icons. In many cases Pro/E will make educated guesses as to the users selection in these menus, to save time moving the mouse the
2. The Model Tree window gives a graphical representation of the method of the part construction, i.e. the order of Features. The tree can also be used to select individual or groups of features as a alternative to selection in the drawing window. This functionality becomes increasingly useful as the model complexity increases. Features can also be moved in the tree with a simple drag and drop operation provided there are no parent-child conflicts.

N.B. Quick access to feature modifying functions can be gained via the RMB whilst over the Model Tree.

The layout and information displayed is user definable via the icons and pulldown menus at the top of the window.

You should bear in mind that Pro/E is a specialist package, and the designers who use it would normally do so full time, after an extended training period: so don't be surprised if you find it more difficult to use than other CAD software that you may already know.

Central to the use of the package is the ability to obtain the best view of the object you are constructing, e.g. the orientation and the display mode. Access to commands effecting the display are concentrated under the View pull down menu and the top icon bar. In addition the orientation can be manipulated with a combination of the Ctrl/Shift keys and the mouse.

<u>Key/Mouse</u>	<u>Action</u>
(N.B. The Ctrl key can normally be released once the action has been initiated.)	
Ctrl - Middle Mouse Button	Zoom in/out
- Middle Mouse Button	Spin
Shift - Right Mouse Button	Translate

4.3 Sketcher

Central to the use of the 'sketched' features is the use of the sketcher or sketch mode. This is basically a complex drawing program which allows profiles to be drawn that are subsequently extruded/revolved/swept etc through 3-D space to modify the item being constructed.

Built into the package is knowledge of how things are typically constructed, e.g. lines are often parallel, similarly sized sketched entities are likely to be identical. The system uses these 'Assumptions' to apply overridable 'Constraints' to the sketch, e.g. vertical/horizontal line, to simplify the drawing the profile.

It should be noted that the assumptions taken by the system are partial dependent on the screen scale.

- **Sketching Tools**

The sketcher has many commands/functions that are accessible either from the SKETCH pull-down menu, via the side icon bar or from context sensitive floating menus accessed via the RMB. In addition a number are mapped to standard CUED hotkey sequences, see below.

The main drawing commands are found in the following sub-menus:

GEOMETRY **Mouse Sketch, Lines, Arc, Circle, Rectangle and Point.**

GEOM TOOLS **Intersect, Trim, Divide, Use edge, Mirror and Move.**

SEC INFO information about the sketched entities, including intersect and tangent points, angles, distances etc.

- **Sketcher Assumptions**

The knowledge model underpinning both operational modes attempts to apply constraints based on the following assumptions about the users intent:

Equal radii and diameters, symmetry, horizontal and vertical lines, parallel and perpendicular lines, tangency, 90 and 180 degrees arcs, collinearity, equal segment lengths, point entities lying on other entities, and centres lying on same horizontal or vertical.

More detailed information on these assumptions can be found in the user manuals.

- **Sketcher Tips**

- Keep sketches simple, you can add other features later.
- Use sketcher grid to aid construction (can also set grid snap from the UTILITIES → ENVIRONMENT menu)
- Do not use **Modify**, i.e. apply physical dimensions, until a section is (nearly) complete.
With the intent manager inactive
- Create sketches in steps, and regenerate each step as you progress.
- Use **Unregenerate** to restore sections to their previous state.

4.4 Mapkeys - Hotkeys/Keyboard Shorts

The complexity of a full function CAD package means that it can be difficult/time consuming to access a particular command/set of commands. ProE offers a hot key functionality in addition to the pulldown menus/icons and floating menus to aid efficiency. There are a set of CUED standard hot key sequences that should be available on all systems. Most are two character commands that can be most easily accessed assuming a right hand mouse operation and a left hand on the keyboard. (See the table at the end of this document)

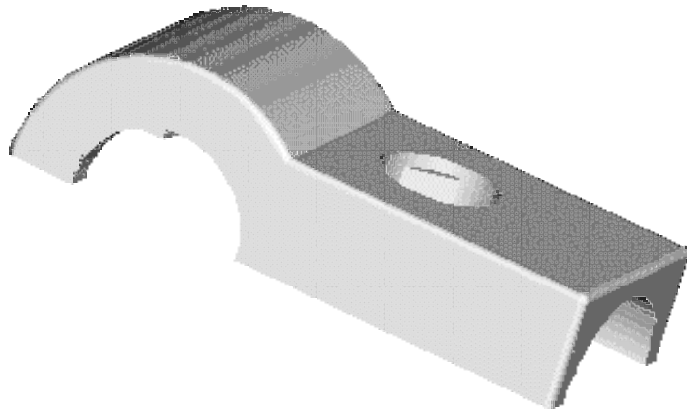

Figure 3: Shaded view of the completed worked example.

5 Worked Example: Clamp

This section is a guided tutorial to produce a model of a clamp as shown in figure 5. The tutorial is laid out in subsections corresponding to the construction of individual features within the model.

Detailed descriptions are given of the construction of the initial features, as the guide progresses information is limited to only the new commands being employed.

As in the physical production of an item there is often a more than one way of construction, with no one ‘correct’ method. The construction techniques used here have been chosen to show a range of features and their of method of usage rather than a definitive solution.

5.1 Start ProEngineer

If not already running initiate the system as described in the getting started section, e.g. by typing `mwm &` followed by `run-on-terminal proewildfire2`.

To change to the directory used to save files select FILE → **Set Working Directory** (or use the hotkey option `cd`) and then select the required directory.

5.2 Creating a part

The creation of a new part involves the generation of a file together with default coordinate system, datum planes and material properties etc. While this can be achieved using individual commands (see Appendix A), it is highly recommended that the CUED default ‘start part’ is used.

Use the LMB to select NEW PART icon () on the top menu bar, this will start an automatic procedure to generate a new part using the default CUED settings.



After a few seconds a menu will appear prompting for the name of a part, e.g. *clamp*, and then press ENTER or click (LMB) on OK.

This will initiate a procedure to set up the default coordinate system and datum planes (Front, Mid, Top) which will be appear in the main window.

N.B. The brown Datum icons () on the top icon bar can be used to toggle the display of datum features

In addition to the default datums a number of other part paramenterers have been set by using CUED start-part. If you need to change any paramenter/ use the additional functionality please refer tot he online help or the manuals.

5.3 Initial Material Feature / Protrusion

Create a base protrusion (stock material) by selecting the Extrude Tool icon () from the right hand icon-bar, this will initiate the 'Extrude Dashboard' () just below the message window.

It is possible to use an exisiting sketch as the basis of a sketched feature, here however use the internal sketch option by RMB→Define Internal Sketch.



Section Menu

1. Sketch Plane

This will open a SECTION window and a prompt in the message window to "Select a plane or surface to define sketch plane". Moving the mouse over the main window will highlight (in light blue) each of the possible sketch planes.

Using the LMB, select the plane FRONT when highlighted or the Model Tree window.

Immediately the menu will be populated with default values and also indicated on the main window.

An arrow indicates the direction of view of the sketch plane

The direction can be changed using the **Flip** menu item, in this example any direction will be suitable.

2. **Sketch Orientation** The sketchplane can be presented on the screen in any angle and a preferred orientation can be selected by using the **reference** and **orientation** menu items. In most cases ProEngineer makes an intelligent guess at the required orientation and therefore the default can be accepted.

In this case choose the defaults, by selecting **Sketch**.

N.B. Sketch is highlighted on a raised button in the menu and can thus be selected as the default option in the menu by pressing the MMB (with the pointer in the main window), see above.

N.B. Standard extrusions can be initiated more simply by using the Ext 1 Side, Ext Revolve and Ext 2 Side, (Extrude 1 side, Extrude revolve and Extrude 2 sides), from the PART menu. N.B. This requires the CUED New Part option to have been used.

3. Dimension References

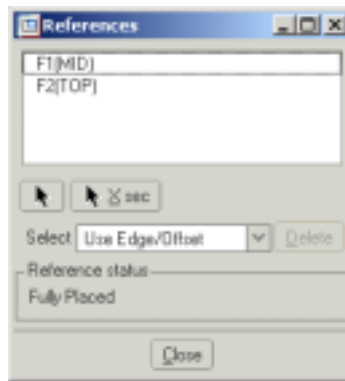

Reference Menu

To automatically dimension any entity drawn the system needs a local dimensioning reference. When the sketcher mode is entered a REFERENCES window is displayed which lists the entities that have been chosen as default references and indicated in the sketching window by brown dash-dot-dot lines.

In this example the default references should be 'F1(MID)' and 'F2(TOP)' thus select (LMB) **Close** . Any further drawing on this plane will be referenced to this temporary coordinate system.

(N.B. It can be useful at this stage to Deselect the Datum Plane icon to simplify display)

4. Sketching a Section

Using The sketch arc(centre/ends) function accessed via either the arc (4th icon down) → centre/ends (3rd icon on the flyout menu) or SKETCH → **Arc** → **Center/Ends** draw a arc centered on the intersection of TOP and MID. LMB to select circle center, start and finish.

Complete a rough sketch of the remained of the profile section as shown in Figure 5 using the line draw facility. This can either be accessed via the RMB/flying menu or the icon/menu options as used for the arc.

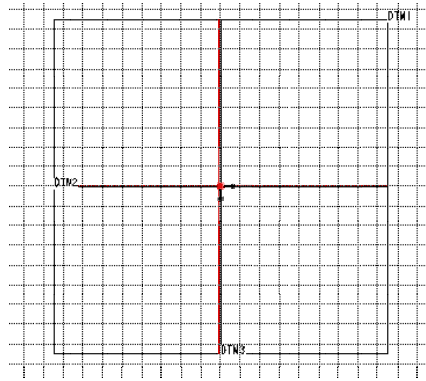



Figure 4: Initial sketcher mode layout.

To delete unwanted items, select the entity (line will turn red) and then select delete by holding down RMB → Delete. Multiple entities can be selected by dragging a boundary using the LMB

(Should artifacts be left on the window use VIEW → Repaint, the Repaint icon on the top menu bar () or the hot-key sequences (CTRL) + R or vr) to refresh the screen.

Note :

- (a) The pointer has 'intelligence' and snaps as it approaches an intersection/circle centre/line etc
- (b) Pressing MMB once while drawing an entity will abort the operation and return to the standard select option.

Once drawn the system will allocate default dimensions to the entities, which are displayed in grey. The values are based on the screen resolution/setup and any previous components of the part.

(It is worthwhile spending some time familiarising yourself with the sketcher mode - add lines, rectangles etc and then delete them.)

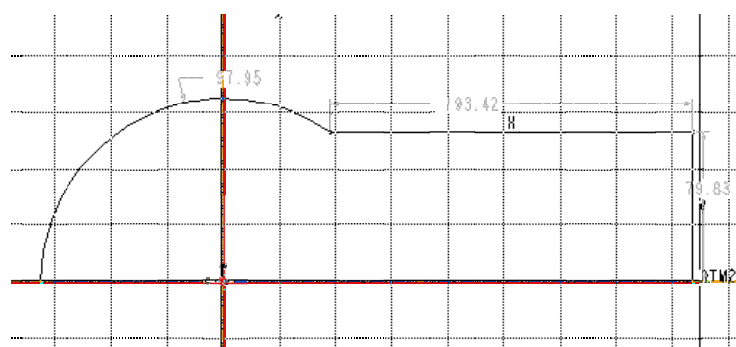

Figure 5: Rough sketch of profile section.

5. **Modifying a Sketch** Dimensions on the sketch can be simple modified to a precise value by double clicking on the screen value and entering the correct figure at the prompt. A more dynamic, but less precise method of modification is available by selecting (LMB) and dragging and dropping a sketch entity, e.g. a line.

6. **Redimensioning a Sketch** Although the system automatically places default (soft) dimensions, which are used to generate drawings etc., it often useful to choose alternative dimensions. In this case an alternative dimension from the vertical reference to right hand end can be defined using the dimension function (accessed via the floating menu, side bar icons, SKETCH menu or hotkey *sd* (Sketch Dimension)).

To place the dimension select the entities and then place with the MMB, i.e. select (LMB) the vertical reference, righthand vertical of the section and MMB to place dimension above the section.

7. **Sketcher Exit** To exit the sketcher mode select SKETCH → **Done** or the ‘Tick’ on the side icon bar.

8. **Solid/Surface** ()

Leave the default setting of the second and third dashboard icons, e.g. the ”extrude as solid” option (second icon) selected.





9. **Profile Depth** The left depth icon allows the user to select details of the extent of the extrusion, here select symmetrical two-side.

Adjust the depth to 32 by chosing one of the following techniques:

- (a) Enter value in the field on dashboard
- (b) Selecting and dragging the square handle (small white square, on axis) on the extrusion in the main window. Note it can be difficult to accurately choose a value using this technique.
- (c) Double clicking, with LMB, on the dimension in the main window and entering the required value.

10. **Verify/Preview** ()



The defined feature can now be temporarily previewed by verify icon () from the right hand end of the dashboard. If an error exists individual elements of the protrusion can be modified by re-selecting the appropriate icon.

11. **Exit** ()

Once completed the protrusion can be accepted by selecting the tick (). N.B. Selecting the cross will cancel the generation of the feature.

5.4 Review/Display

The Protrusion can now be rotated and/shaded to improve the view of the feature.

1. Press the MMB to rotate the model. Use SHIFT and CTRL to zoom and pan.
2. Select **Shading**, **Wireframe** etc icons ()
3. You can also reset the view and repaint it. These options are available by choosing **VIEW** pull down menu or from the icon bar () .

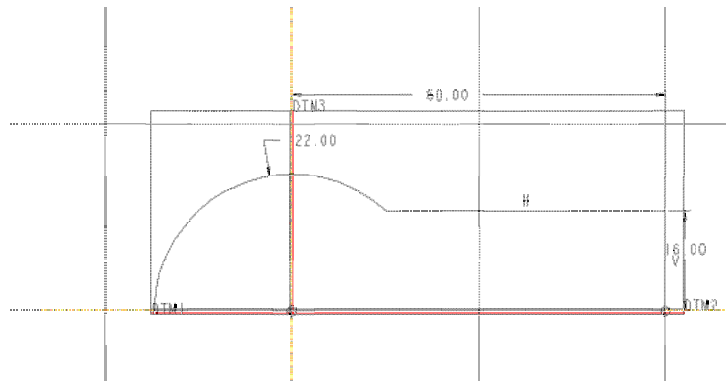

Figure 6: Re-dimensioned profile section.

5.5 Edit Profile Dimensions

There are several ways of modifying a features dimensions

1. Select the feature (Protrusion idxxx) in the Model Tree or drawing screen, (Highlight protrusion feature in light blue and select with LMB) and the using the RMB select **Edit**. The defining dimensions are displayed in the main window, Select the value to be modified (double click LMB) and enter the value at the prompt.
2. Again select the required feature and in the flyout menu (RMB) select **Edit Definition** which will return to the protrusion dashboard.

Modify the radius to *22*, height to *16* and center/end dimension to *60* as shown in Figure 6. Dimension values are changed from yellow to white when modified. To action the modifications select **Regenerate** from the EDIT menu, the image will animate to the new dimensions.

(N.B. The regenerate function can also be actioned by (a) Using the hotkeys rg (b) Selecting the Regenerate icon 

5.6 Save Part

Use the FILE → **Save** function or save icon () to save the part in its current form.

5.7 Extruded 'Cut' using a surface reference

Create the end cutout using the remove material option in the extrude feature () to generate the semi-circular cut in the end of the protrusion.

1. **Define Internal Sketch** RMB → Define Internal Sketch and the select the end face of the protrusion as the sketching plane, and accept the defaults for the direction and orientation.

Accept the default dimension references.

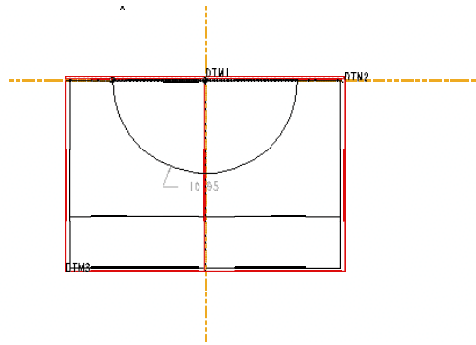

Figure 7: Rough sketch of Cut section.

2. **Sketch.** Using the arc drawing and line drawing functions, as used to define the extrusion, generate a closed semi-circular section centered on the intersection of FRONT and TOP, see Figure 7.

Adjust the cut to have a diameter of 25.4mm. (ProE defaults to radius dimensions)

Select the dimension function (icon, RMB or SKETCH menu), double click LMB on arc (single click for radius) and use MMB to place dimension. Note the change in the dimension format and the removal of the soft (default/grey) dimension.





To modify the dimension value either:

- Single click (LMB) on the dimension to be modified and then use the EDIT menu or RMB to select **Modify**. The resulting MODIFY DIMENSIONS menu allows dimensions to be modified (25.4mm) either using the writable field or the 'Thumb Knob'.

N.B. By default the automatic **Regenerate** option is selected which causes the sketch to be dynamically updated. When a number of dimensions need to be adjusted it may be need to unslect this option to avoid difficulties.

- Double click (LMB) brings up a simple edit box to enter the required value (25.4mm) ENTER or select 'Tick' to modify.

Exit the sketch with 'Tick' ().

3. **Depth** () Accept the default ("Extrude from sketch plane by a specified depth value.") and adjust the depth to 20.
4. **Cut** () Switch from a material extrude to a cut by selecting the cut icon (radio button down).
5. **Preview** () Use the Verify/Preview icon to check the cut is correct.
6. **Cut (material) Direction** () if required, use the material direction function to swap the side of the section that is cut.
7. **Exit** () Exit the extrude (cut) tool.

5.8 'Both' sided cut feature

Again use the extrude/remove feature, using the two-sided option, to generate the hollowed section under the curved section of the protrusion.

1. **Section** Select the FRONT plane as the sketching plane, and accept the defaults for the direction and orientation.

Accept the default dimension references. (Deselect **Datum Plane** icon to simplify display)

Sketch, using Arc or Circle functions combined with the line function, (Accessed from the Sketch Menu or RMB or side icons) an approximation of the cut section centered on the intersection of FRONT and TOP, see Figure 8.

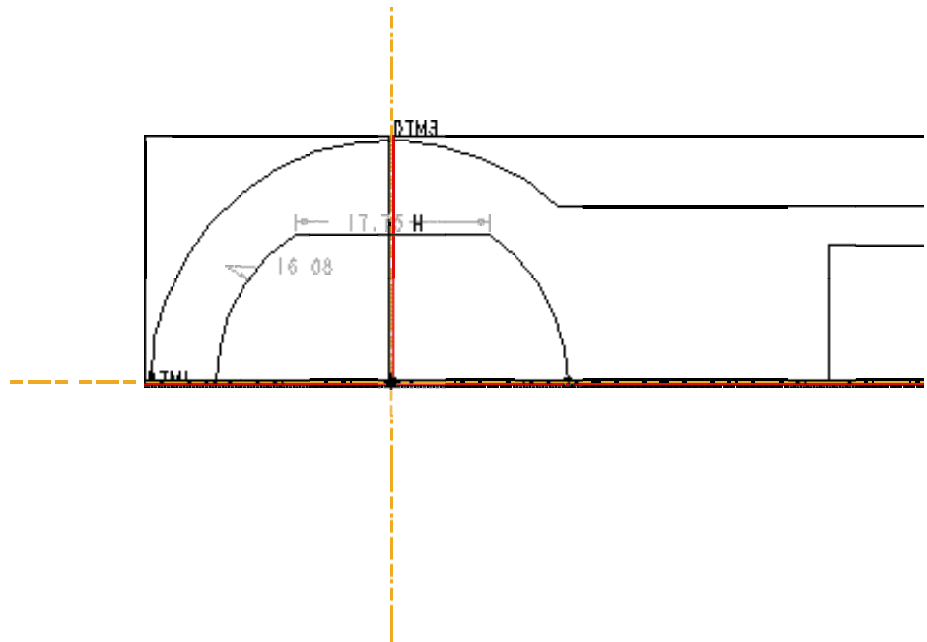







Figure 8: Rough sketch of Cut section.

Tidy sketch using either

- The trim function (EDIT → **Trim** → **Corner** or third icon from bottom of the side icons) to delete unwanted lines.
 - Break the sketched entities at intersections by using the ‘Devide Entity’ tool, on the same fly out menu as trim. Delete the unwanted lines using select (LMB) followed by RMB → **Delete**. N.B. Intersections generated are highlighted with a yellow dot.
2. **Dimensions** Using Modify and Dimension tools set the cut radius to *18* and base to flat section to *15*. Exit sketch mode with **Done** or ‘Tick’.
 3. **Depth** Set the extrusion to be a symmetrical two-sided, with a total depth of 24mm.
 4. **Cut** () Switch from a material extrude to a cut by selecting the cut icon (radio button down).
 5. **Preview** () Use the Verify/Preview icon to check the cut.
 6. **Cut (material) Direction** () if required, use the material direction function to swap the side of the section that is cut.
 7. **Exit** () Exit the extrude (cut) tool.

5.9 Pick & Placed Hole

() Using the hole feature generate the 25mm diameter circular hole through side webs under the curved section of the protrusion. Figure 9 shows the hole dashboard.

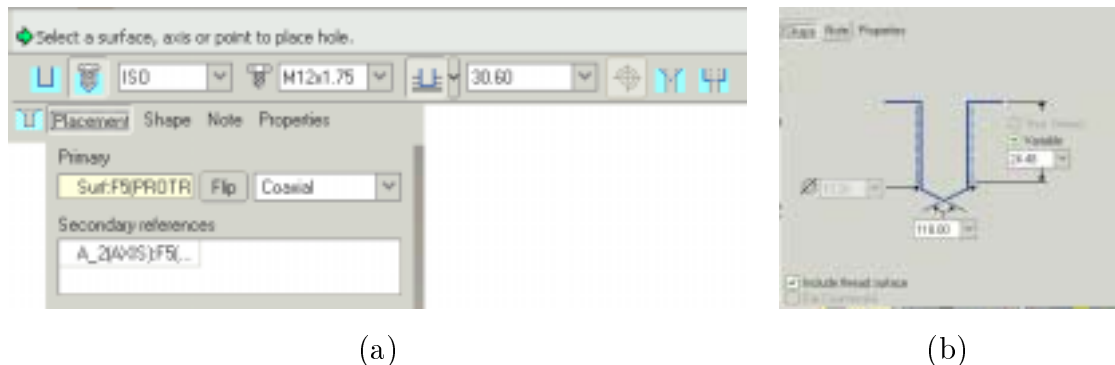



Figure 9: Hole dashboard. (a) Placement options & (b) Shape Options

1. **Hole Placement** requires three references the initial placement plane and two entities to dimension the hole in x/y space.
 - Select the side of the protrusion as the placement plane.
 - Select the planes MID and TOP as the dimension references and align the hole by setting both offset **Distances** to 0mm
2. **Feature** → **Create** → **Hole** initialises the general purpose HOLE generation menu.

3. Select **Hole Type** → **Straight Hole**
4. Set **Hole Dimension** → **Diameter 24.5** and **Depth One Thru All**
5. Preview/(Define)/Tick before inspecting the resultant component.

N.B. A note is added to give information about the hole. To switch this off select TOOLS → Environment and then deselect 3De Notes () or use the hotkey '3d'.

5.10 Sketched Hole

In addition to a straight sided hole the hole function allows for the automatic generation of standard holes, e.g. thread and clearance holes, and special variable cross-section holes. generation of shaped holes, e.g. cone seated pressure seals.

Here the **Sketcher** is used to generate the basic shape for the hole in the center of the item. N.B. This is a unique combination of a Pick & Place feature with an element of a sketched feature.

1. **Hole tool** Select the hole feature as with the last hole, but select the **Hole Type** → **Sketched**
2. The system produces the sketched hole in a similar manner to a revolved cut feature and therefore expects a sketch of half the hole profile and a centreline as an axis of rotation. However, unlike a revolved CUT (or Protrusion) no references are required. Thus once a sketched hole has been selected a empty standard sketcher window is initialised.

Start by placing a vertical centreline using a RMB → **Centreline** and then click (LMB) drag to align vertical.

Then sketch the shape of half the hole, see Figure 10. N.B. To change the default radius dimensions to diameters, select **Dimension** followed by the point of reference, the centreline and the point of reference before placing the dimension with the MMB. This functionality is available in all revolved features.

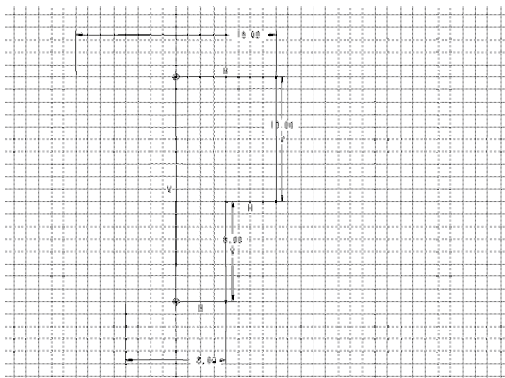

Figure 10: Rough sketch of the sketched hole section.

- g Select **Tick** when complete, and continue the placement process as with a straight hole.
3. In the PLACEMENT menu select **Linear** → **Done** this will now start a sketcher window in which to define the hole cross-section prior to continuing with the placement definition.
 4. Select the top of the protrusion as the Primary Placement Reference and the central datum plane (FRONT, Offset Distance 0mm) and the end of the protrusion (Offset Distance 30mm) as the **Linear References**.
 5. Preview, Update, Tick before inspecting the resultant component.
 6. Use the select feature RMB→Edit to change the hole dimensions. Small diameter, 8, Large diameter, 16, Overall depth 16, Large diameter depth 10. (**Regenerate** to update the values)

This function is very similar to the revolved cut!. (Select the generated feature and RMB→suppress to remove it from calculations. Now try and regenerate the feature using the revolve/cut feature)

5.11 Protrusion - adding material

The nut retaining surfaces in the sketched hole can be produced using the Protrusion feature to add material to an existing item. In this case use the sketch + feature method of construction, i.e.

1. Sketch Item: Select the sketch feature icon and using the base of the large diameter hole as the sketching plane,
 - Select FRONT or **Default** as the additional reference.
 - In a similar manner as the sketched entities produced above, existing datum planes, i.e. FRONT and MID, can be used as the sketching references. However, a simpler and more appropriate reference is the existing hole, i.e. select the edge or central axis of the sketched hole.

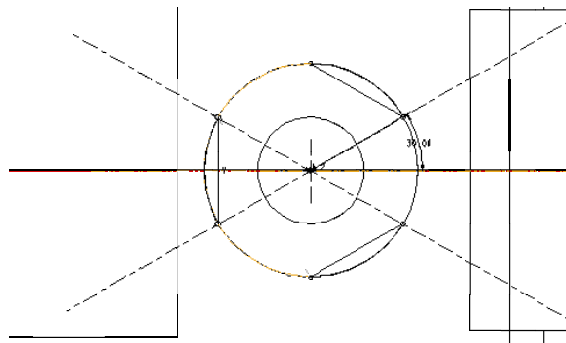

Figure 11: Sketch of the nut retaining protrusion, showing the use of centrelines.

- Using centrelines set at 30° sketch the three inserts, as shown in Figure 11. Use the **arc** and **line** commands to generate the general shape. If an error of unclosed section(s) is given on selecting **Done/Tick** use **Edit** → **Trim** (or icon entry) to join/trim the straight and arc lines.
 - Exit the sketcher, notice the sketch feature in the model tree
2. Extrusion: Select the extrude tool and extrude the retaining surfaces using the predefined sketch. Set a blind depth of 8
 3. Preview/(Define)/OK

5.12 Ribs

An alternative to a protrusion for a thin extrusion is a **Rib**. This is very similar but only requires the external surfaces to be defined. To produce one of the small reinforcing webs under the curved section of the clamp, but not aligned to an existing surface a **Rib** can be used drawn using an attached datum.

An attached Datum is identical to a normal datum plane but is directly associated with a feature. It is used here to dimension the rib from the center of the object to enable the feature to be patterned. N.B. This method of construction is essential for the patterning of features around a diameter.

1. Select the rib tool
2. Select the option to use an internal sketch
3. When prompted for a sketch plane add a datum using the icons from the righthand icon bar. These datums are constructed with relation to other preexisting features, in this example the required sketching plane is parallel/offset from FRONT. Selecting front will give the option of adding an offset, 7.
4. Select TOP (or **Default**) as the second reference plane
5. Specify MID and TOP as positional references
6. Sketch a single line to represent the diagonal edge of the web and dimension as shown in Figure 12, 7 horizontal, 10 vertical.
7. Accept the sketch and enter a thickness of 2 mm.

Repeat the above construction technique, using FRONT as the sketching plane, to generate the large rib and dimension as shown in Figure 13. Thickness 2 .

5.13 Patterned Feature

Patterning is a very powerful tool that allows feature, or groups of features to be repeated according to a geometrical rule without having to reconstruct the feature. It is often used to pattern around an axis, e.g. to generate a set of holes on a PCD. To generate the second small rib

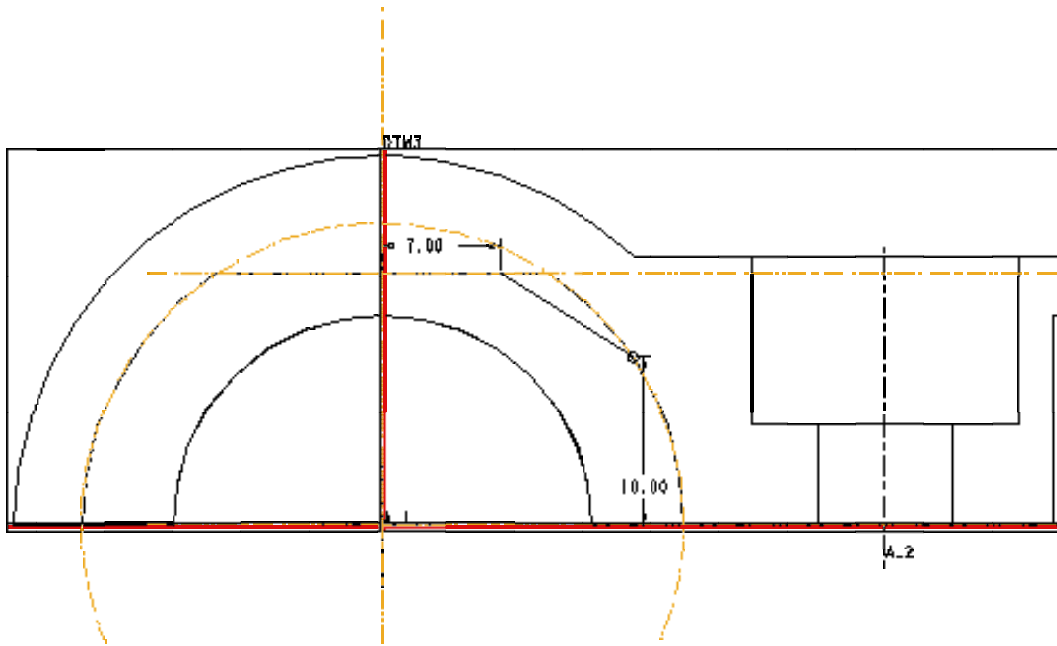



Figure 12: Sketch showing the simple definition required for a rib

- Select the pattern tool
- Select the offset dimension from FRONT as the driving parameter, and enter the increment -14.
- 2 to generate 2 copies of the rib in the pattern.

5.14 Rounds

The **Rounds & Chamfer** features are normally added as the last constructional details on an object, as in the physical construction process. This eliminates unwanted problems resulting from subsequent features removing the reference edge/surface and also to reduce the computational burden of continuously displaying complex surfaces.

To add the rounded edges to the clamp, select the round tool icon () or (INSERT→Round ...) starts the 'round' dashboard and a message prompt 'Select and edge or chain of edges, or a surface to create a round set'.



1. **Radius** Set the round radius to 1 mm.
2. **Edges** Although there are a large number of options, accept the defaults and using the highlight/select function select the two outer edges of the spacer.

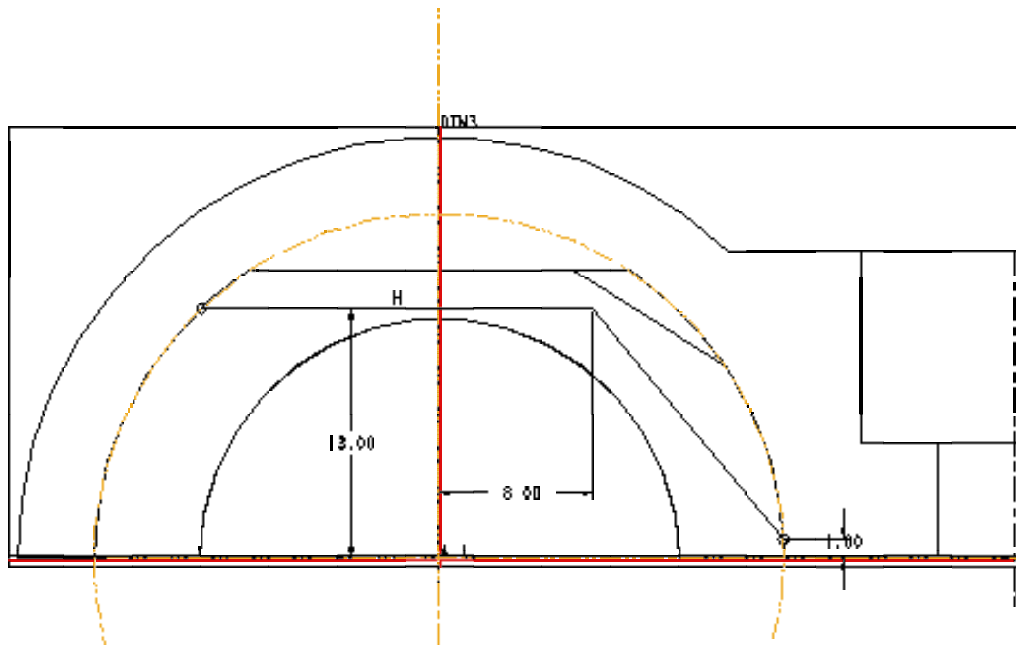

Figure 13: Dimensions of the large reinforcing rib

N.B. the most recently accepted edge is highlighted in red and is dynamically adjustable.

3. **Review** Check, preview and Exit round tool

6 2-D Drawing

Even though the direct link from CAD to CAM (Computer aided manufacture) is increasingly common there is still a need to produce 2-D drawings, in ProE this is a relatively painless procedure as the hard work has already been completed in the model generation. Note that the drawing views are associative. If a dimension is changed in one view and regenerated, all of the views update and so will the entire model.

6.1 Laying out a Drawing

6.2 Start a Drawing

To open a new drawing select **FILE**→**New**→**drawing**. Enter the name of the drawing, e.g. *clamp* and select **OK**

The **NEW DRAWING** menu should now appear, ensure that the default model field is *clamp.prt*, ensure the **Empty with format** option is selected and the format field is *a4-part.frm*. Selecting **OK** will initiate the drawing window and open the **DRAWING** and **DETAIL** menus.

6.3 First View

To generate and locate the first view

1. **Insert View** select RMB → **Insert Drawing View** or INSERT → **Drawing View**
2. **View Type** in the VIEW TYPE menu accept the default values of **General** → **Full View** → **No Xsec** → **No Scale** → **Done** or MMB.
3. **Placement** The user is now requested to choose the location for the master view by a prompt in the message window ‘select CENTER POINT for drawing view. Selecting (LMB) a position near the bottom right of the drawing surface will result in a default (isometric) view being placed followed by the opening of an ORIENTATION window, see Figure 14.
4. **Oriente View** The Orientation functions can be used to obtain the direction of a view. Using the CUED start part a number of **Saved Views** are available and normally enable the initial view to be placed simply. (You need to click on the white arrow beside the SAVED VIEWS title to expose the full menu).

A suitable master view for this drawing is FRONT, select **Saved Views**→**Front** and then **Set** → **OK**. (N.B. It is important to select **Set** before **OK**.)

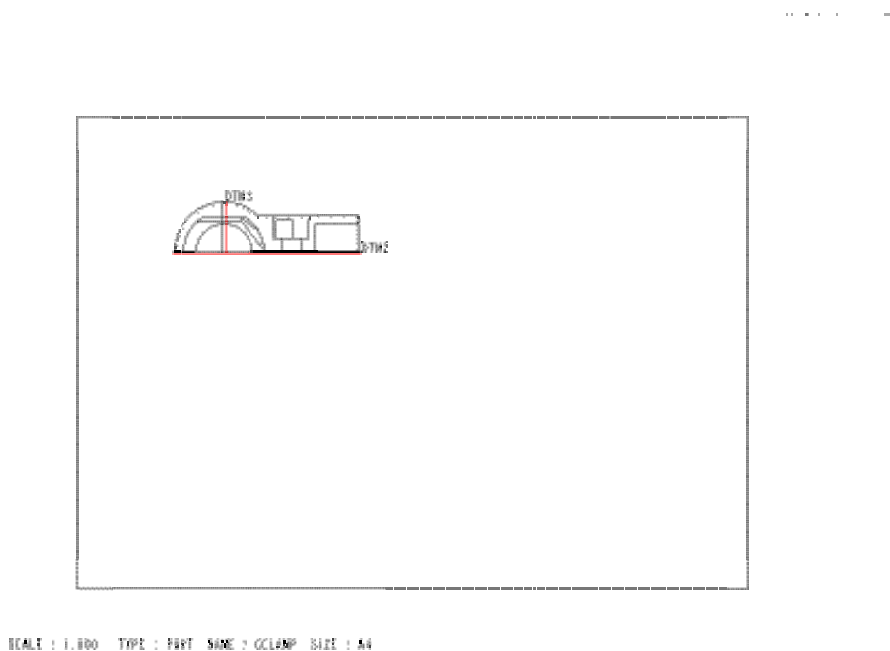

Figure 14: Orientation of the initial drawing view

6.4 Additional Views

Additional views can now be added, with the view orientated automatically. Using the default menu choices add two more views to your drawing.





1. **Add View** Use RMB → **Insert Drawing View**, () or INSERT → **Drawing View** to initiate the generation of new views.
2. **View Type** In the VIEW TYPE menu accept the defaults (**Projection*** → **Full View** → **No Xsec** → **No Scale** → **Done**) or MMB.
N.B. Once the initial view has been placed the system assumes that subsequent views are projections.
3. **Placement** Use the LMB over the drawing area to select the position of the two views, the system will ensure that the correct projection is shown.
4. **Relocate views** Using LMB to select a view (highlighted in with a red box) and then holding LMB down drag the view to the required location. Select with LMB in a clear area of the drawing to deselect a view. (If the view does not move deselect the 'Lock View Movement' from the RMB context sensitive menu)
5. **Set Display mode** Select the **Hidden Line** display option (   ) on the icon bar and deselect the datum icons to display a clean drawing. N.B. **No Hidden** (and **Wireframe**) can be used if required.
6. **Setting the Drawing Scale** To change the overall scale of a drawing double click LMB on the scale information at the bottom left of the main window. At the prompt line enter the value you require, 0.4 is a suitable scale for this drawing.
N.B. Normally drawings scales are limited to multiples of standard scales, e.g. 1:1 1:2 1:2.5 1:4 1:5 (1, 0.5, 0.4, 0.25, 0.2)





Figure 15: (a) Show-Erase Menu (b) Accept All

6.5 Display Centerlines

Select VIEW → **Show/Erase** or () to open the SHOW/ERASE window.

Select the axis icon and **Show All**, see Figure 15(a), confirm 'Are you sure that you want to show all?' and then **Accept All**

6.6 Drawing Dimensions

To dimension the drawing use the same 'Show and Erase' function () as above (section [refsec:clines](#)). Select **show** () and **dimension** () → **ShowAll** → **Accept All**.

6.7 Tidy Drawing

The position of symbols and text can be moved using the LMB to select a item which can then be dragged to the required position. MMB to stop, LMB to exit move.

A large number functions are available via the RMB context sensitive menus, see Figure 16, and from the INSERT and FORMAT menus. (See FORMAT → **Decimal Places**.. to change default number display and therefore implied accuracy)

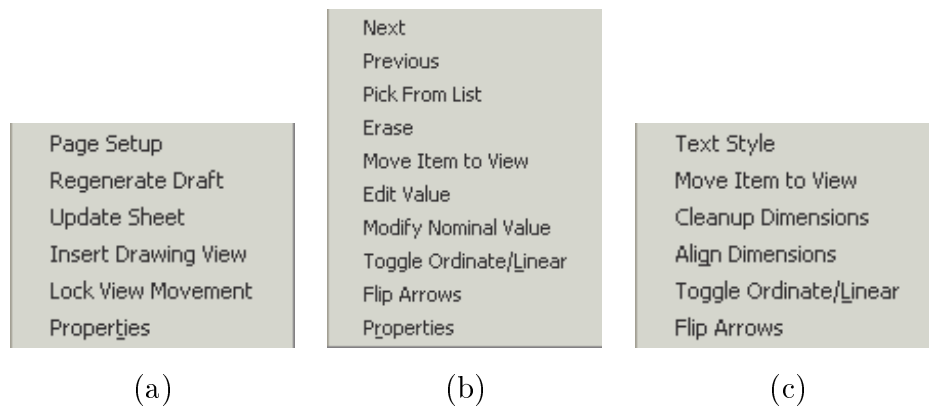
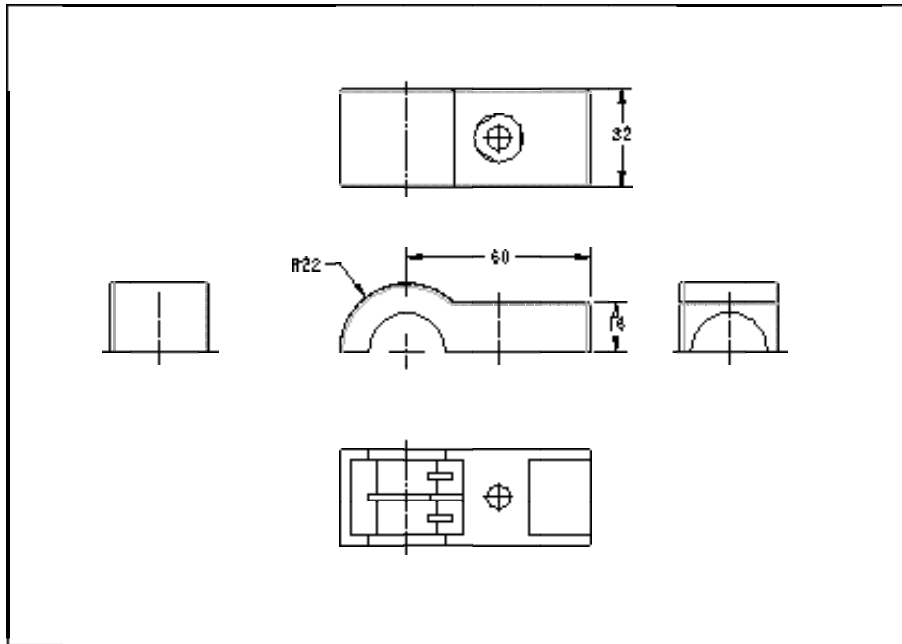

Figure 16: Examples of context sensitive Pull out Menus, (a) On background (b) On selection of 1 dimension (c) Multiple dimension selection

Use the functions, details about some are given below, to tidy the dimensioning etc. (Also see Figure 17)

1. **Cleanup Dimensions** Multiple selection → RMB automatically aligns dimensions on a user definable spacing.
2. **Move Item to View** Single or Multiple selection allows dimension etc to be switched between views.
3. **Flip Arrows** Single or Multiple selection allows dimension arrows to be realigned
4. **Properties (Background)** Allows sheet/layout to be changed
5. **Properties (Single)** Change value, format, font etc.
6. **Text Style** Change text in multiple dimensions etc.



SCALE : 1.000 TYPE : PART NAME : CLAMP SIZE : A4

Figure 17: Example of partially dimensions drawing of the clamp

6.8 Isometric View

The advantage of CAD is that it is relatively easy to add additional views. It is often useful to add an Isometric view to aid visualisation. To add a general view select RMB → **Insert Drawing View** or  Accept the default settings, except choose **General** instead of **Projection**, and **Scale** instead of **No Scale**. Place and orientate the view in a blank part of the drawing, see Figure 17.

6.9 Printing a Drawing

Printing to Postscript printers is relatively easy from Version 20 of ProE onwards:

- select the printer icon or **Print** from the **File** pull down menu.
- Select **Generic Postscript**
- Enter printer command, e.g. lp -d1jmr1 for the laser printer on the teaching system.

For access to large format printers or colour output contact the computer operators or the Design Office.

7 appendix

7.1 Part (Assembly) Colour

By default the colour of a part is Grey, however in many cases it can help visualisation/manipulation to change the colour of the whole or a part of an entity. As an example colour the bottom flat surface of the clamp red.

Select the APPEARANCES menu, (VIEW → **Color & Appearances**

7.2 Relations

The parametric nature of ProE allows model variables to be set as fixed values or written as a function. These **Relations** can be a algebraic function that is dependent on another model variable, for example ensure that the diameter of the hole under the reinforced section of the clamp is the same as the cut in the end:

- Choose Tools → **Relations**. Read the prompt.
- Select the hole and cut, from the drawing or model tree, to display their dimensions in symbolic form (i.e. d2, d3, etc).
- Note the symbolic dimensions that defines the hole diameter and cut radius, e.g d11 , Rd4.
- Select **Add** from the RELATIONS menu which will open a prompt window.
- Enter the relation $d4=d11/2$ <CR>
- Comments, which are essential on complex models, can be added to the relations by prefixing text with `/* Clamping diameters equal`.
- Further relations can be added to make all feature parameters a function of one dimension, e.g. clamping diameter. To finish enter <CR> on a blank prompt line.
- Use **Switch Dim** from the RELATIONS menu to toggle dimensions between their symbolic and numeric forms.
- Select **Done** from the MODEL REL menu → **Regenerate**.
- If an error in the relations, select **Relations** → **Edit Rel**. This will display the current relations in the text editor. Correct any errors, saved the file and exit the editor before **Regenerating** again.

Create a New Part by selecting **New** from the **File** pull down menu, followed by selecting **Part** and entering a filename, e.g. clamp, followed by **OK**.

At this stage the Menu Manager (PART sub-menu) and Model tree windows will appear, it is normal to locate these to the left of the drawing window.

7.3 Default Csys & Datum Planes

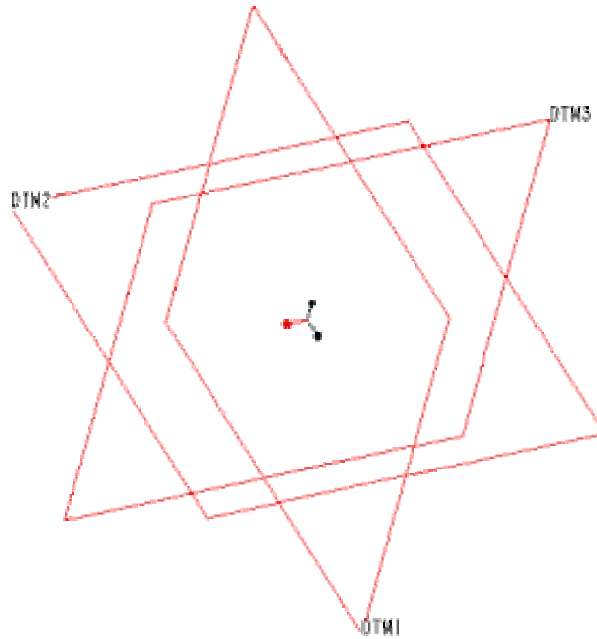

Figure 18: Default Datum Planes

Create default Csys and Datum Planes from the PART sub-menu, i.e.

- Select **Feature** → **Create** → **Datum** → **Coord Sys**
- Select **Feature** → **Create** → **Datum** → **Plane** → **Default**

N.B. It is also possible to insert default planes/coordinate system using the Datum menu to the side of the main creen. this is available at all times.

Figure 18 shows the resulting screen display. The creation of a new part and datum plans can be automated by selecting the CUED icon **New Part** that results in a similar display but with the datum planes renamed Front, Top and Mid and a prompt for the part name.

P.J.G. Long
May 10, 2004

CUED Design Office - ProEngineer Wildfire v.1 - Hotkey Defaults

pjl2@eng.cam.ac.uk
Rev17 15/01/04

General Commands	aa Okay accept	dd Done	dr Done Return	ds Done Select	ff Flip direction	fx/fq Feature exit	ra Regenerate All	rg ReGenerate	xf cancel Feature	ee Edit	ef Edit Feature	sc Set Colour			
File Options	fa Find Assembly	fd Find Drawing	fw Find part	na New Assembly	nw New Part	nd New Drawing	cw Change Window	qe/se Quit / save Erase	qp Quit / save Purge	qs Quit & Save	qw Quit Window	sp Save Purge	sw Save Window	cd/wcd Change Directory	wn Window New
Environment Options Normally preceded by 'e' (Environment)	ew Wireframe	eh Hidden line	en No hidden line	es/vs Shaded	ed display Datum Planes	ea display Axes	ec display Coord Sys	el display Spin Center	ep display datum Points	er Reset/ogle datums	et Enable Transparency	te disEnable Transparency	gs Grid Snap	dt Default Tiff colour map	at Alternate Tiff colour map
View Options Normally preceded by 'v' (View)	va All/refit	vr Repaint	vd Default	rv reset	vz Zoom	vp/zv Previous	v spin	ve View Explode	ev unExplode View	vf Front	vt Top	vm Bottom	v> right	v< left	vb Back
Blank/Display Layers Normally preceded by 'b'-(Blank) 'x'-(Expose)	bx all	ba/xa Axes	bc/xc Cuts	bd/xd Datum Planes	bh/xh Holes	bn/xn Notes	bt/xt cosmetic e.g. Threads	by/xy sYmbols	bz/xz Dimensions	F1 / F8 xDatum Fn Plane					
Sketcher Options Normally preceded by 's' (Sketcher)	sa Sketcher Alignment	sd Sketcher Dimension	se use Edge	sf Fillet	sc/cl Centerline	st Trim	sx delete	xs undelete	sq Sketcher Quit	sr Reset view	ss Start Sketcher	sv Sketch View (2D)			
Create Options Normally preceded by 'c' (Create)	ch Create Hole	cr Create Revolve	cc Create Chamfer	cs Create Shell	ce Create Extrude			slh Centerline Horizontal	slv Centerline Vertical	sm Move					
Detail Options Normally preceded by 'd' (Detail)	da show Axis	ad erase Axis	dc Clip line	dd show dimension	de modify/Edit text	df Flip Arrows	dl create note with Leader	dm Move	dn create Note	dp mod attach (Pointer)	dt move Text	dv switch View	dx Erase dimension		
Plotter/Printer Options Normally preceded by 'p' (Printer)	dm Move	df Flip Arrows	dv switch View	dc Clip line	dn create Note	dl create note with Leader	dx Erase dimension	da show Axis	dp mod attach (Pointer)	da Display Axis	de modify/Edit text	dt move Text	dt move Text	dt move Text	dt move Text
Detail Options Normally preceded by 'd' (Detail)	dm Move	df Flip Arrows	dv switch View	dc Clip line	dn create Note	dl create note with Leader	dx Erase dimension	da show Axis	dp mod attach (Pointer)	da Display Axis	de modify/Edit text	dt move Text	dt move Text	dt move Text	dt move Text

N.B. Hotkey text appears at the bottom of the drawing window, use <DELETE> or <CR> to erase errors